

An Efficient Method for Simultaneous Map Building and Localization

Uwe D. Hanebeck^a and Joachim Horn^b

^aTechnische Universität München
Institute of Automatic Control Engineering
80290 München, Germany
Email: Uwe.Hanebeck@ei.tum.de

^bSiemens AG, Corporate Technology
Information and Communications
81730 München, Germany
Email: Joachim.Horn@mchp.siemens.de

ABSTRACT

We consider the problem of simultaneously locating an observer and a set of environmental landmarks with respect to an inertial coordinate system, when both the observer position and the landmark positions are initially uncertain. For solving this problem, a new state estimator is introduced, which allows the problem to be consistently solved locally.

1. INTRODUCTION

This paper is concerned with the problem of simultaneously locating an observer and a set of environmental landmarks with respect to an inertial coordinate system, when both the observer position and the landmark positions are uncertain. This problem is also known as "Simultaneous map building and localization" (SMBL).

The SMBL problem can in principle be solved by applying a Kalman filter to the augmented state vector containing the observer's position and the positions of all landmarks.³ However, correct operation is only ensured when the complete covariance matrix is stored.

With the desire to reduce the heavy computational burden, many researchers tried to just manipulate parts of the state vector (and hence of the covariance matrix) at each update step.¹² However, applying the Kalman filter while ignoring correlations leads to too optimistic state estimates and may lead to divergence.²

The Covariance Intersection Filter¹¹ has been introduced for solving the SMBL problem locally. It implicitly considers correlations without explicitly having to store them. However, the estimates are very conservative since whiteness of, for example, the measurement noise cannot be exploited.

Here, a new state estimator is applied to solving the SMBL problem, which also allows local computation. In addition to the Covariance Intersection Filter,¹¹ however, the new filter can exploit additional knowledge about the uncertainties involved.

Section 2 presents the new filter without derivation. Applying this filter to the SMBL problem is discussed in Section 3. Section 4 is concerned with a simple simulation example.

2. THE NEW FILTER

We consider a state space model of the form

$$\underline{x}_{k+1} = \mathbf{A}_k \underline{x}_k + \mathbf{B}_k \underline{u}_k, \quad (1)$$

$$\hat{\underline{y}}_k = \mathbf{H}_k \underline{x}_k + \underline{v}_k^y \quad (2)$$

with additive stochastic noise sources, which are composed of two parts according to

$$\begin{aligned} \underline{u}_k &= \underline{a}_k + \underline{e}_k^u + \underline{c}_k^u \\ \underline{v}_k^y &= \underline{e}_k^y + \underline{c}_k^y : \end{aligned}$$

$\underline{c}_k^u, \underline{c}_k^y$ are assumed to be mutually independent zero mean, white, Gaussian random processes, i.e.,

$$\underline{c}_k^u \sim \underline{N}(\underline{0}; \underline{C}_k^u) ; \quad \underline{c}_k^y \sim \underline{N}(\underline{0}; \underline{C}_k^y) ;$$

and

$$\begin{aligned} \text{Cov f } \underline{c}_n^u; \underline{c}_m^u &= \begin{cases} \underline{C}_n^u & \text{for } n = m; \\ 0 & \text{otherwise;} \end{cases} \\ \text{Cov f } \underline{c}_n^y; \underline{c}_m^y &= \begin{cases} \underline{C}_n^y & \text{for } n = m; \\ 0 & \text{otherwise;} \end{cases} \\ \text{Cov f } \underline{c}_n^u; \underline{c}_m^y &= 0 \text{ for all } n, m ; \end{aligned}$$

where upper bounds $\underline{C}_k^u, \underline{C}_k^y$ for the covariance matrices are known according to

$$\begin{pmatrix} \underline{C}_k^u & \underline{C}_k^u \\ \underline{C}_k^y & \underline{C}_k^y \end{pmatrix} : \quad (3)$$

In contrast, $\underline{e}_k^u, \underline{e}_k^y$ are assumed to be zero mean, possibly correlated, nonwhite, Gaussian random processes with unknown correlation and unknown cross{ correlation, i.e.,

$$\begin{aligned} \text{Cov f } \underline{e}_n^u; \underline{e}_m^u &= \begin{cases} \underline{E}_n^u & \text{for } n = m ; \\ \text{unknown} & \text{otherwise ;} \end{cases} \\ \text{Cov f } \underline{e}_n^y; \underline{e}_m^y &= \begin{cases} \underline{E}_n^y & \text{for } n = m ; \\ \text{unknown} & \text{otherwise ;} \end{cases} \\ \text{Cov f } \underline{e}_n^u; \underline{e}_m^y &= \text{unknown for all } n, m : \end{aligned}$$

Here, upper bounds $\underline{E}_k^u, \underline{E}_k^y$ for the true covariance matrices are given with

$$\begin{pmatrix} \underline{E}_k^u & \underline{E}_k^u \\ \underline{E}_k^y & \underline{E}_k^y \end{pmatrix} : \quad (4)$$

Furthermore, $\underline{c}_k^y, \underline{c}_k^u$ are uncorrelated with $\underline{e}_k^y, \underline{e}_k^u$, i.e.,

$$\begin{aligned} \text{Cov f } \underline{c}_k^y; \underline{e}_k^y &= 0 ; \\ \text{Cov f } \underline{c}_k^y; \underline{e}_k^u &= 0 ; \\ \text{Cov f } \underline{c}_k^u; \underline{e}_k^y &= 0 ; \\ \text{Cov f } \underline{c}_k^u; \underline{e}_k^u &= 0 : \end{aligned}$$

The time update equations of the new Iter are given by

$$\begin{aligned} \underline{x}_{k+1}^p &= \underline{A}_k \underline{x}_k^f + \underline{B}_k \underline{u}_k ; \\ \underline{E}_{k+1}^p &= \frac{1}{0.5} \underline{A}_k \underline{E}_k^f \underline{A}_k^T + \frac{1}{0.5} \underline{B}_k \underline{E}_k^u \underline{B}_k^T ; \\ \underline{C}_{k+1}^p &= \underline{A}_k \underline{C}_k^f \underline{A}_k^T + \underline{B}_k \underline{C}_k^u \underline{B}_k^T \end{aligned}$$

with $\kappa_k \in (-0.5, 0.5)$.

With the following abbreviations

$$\begin{aligned}\mathbf{P}_k^p &= (1 + \lambda_k) \mathbf{E}_k^p + \mathbf{C}_k^p, \\ \mathbf{P}_k^y &= (1 + \lambda_k) \mathbf{E}_k^y + \lambda_k \mathbf{C}_k^y\end{aligned}$$

and

$$\mathbf{P}_k = \mathbf{P}_k^y + \lambda_k \mathbf{H}_k \mathbf{P}_k^p \mathbf{H}_k^T,$$

the measurement update equations of the new filter are given by

$$\begin{aligned}\hat{\mathbf{x}}_k^f &= \hat{\mathbf{x}}_k^p + \lambda_k \bar{\mathbf{C}}_k^p \mathbf{H}_k^T (\mathbf{P}_k)^{-1} (\hat{y}_k - \mathbf{H}_k \hat{\mathbf{x}}_k^p) \\ \mathbf{E}_k^f &= (1 + \lambda_k) \mathbf{E}_k^p - (1 + \lambda_k) \lambda_k \mathbf{E}_k^p \mathbf{H}_k^T (\mathbf{E}_k^y + \lambda_k \mathbf{H}_k \mathbf{E}_k^p \mathbf{H}_k^T)^{-1} \mathbf{H}_k \mathbf{E}_k^p \\ \mathbf{C}_k^f &= \mathbf{P}_k^p - \lambda_k \mathbf{P}_k^p \mathbf{H}_k^T \mathbf{P}_k^{-1} \mathbf{H}_k \mathbf{P}_k^p - \mathbf{E}_k^f.\end{aligned}$$

Border Cases

No Uncertainties with Unknown Correlation

When there are no uncertainties with unknown correlation, the covariance matrices \mathbf{E}_k^p and \mathbf{E}_k^y are set to zero in the above equations. The resulting predicted value and the corresponding covariance matrix are given by

$$\begin{aligned}\hat{\mathbf{x}}_{k+1}^p &= \mathbf{A}_k \hat{\mathbf{x}}_k^f + \mathbf{B}_k \hat{u}_k, \\ \mathbf{C}_{k+1}^p &= \mathbf{A}_k \mathbf{C}_k^f \mathbf{A}_k^T + \mathbf{B}_k \mathbf{C}_k^u \mathbf{B}_k^T.\end{aligned}$$

The resulting equations for the estimated value and its associated covariance matrix are given by

$$\begin{aligned}\hat{\mathbf{x}}_k^f &= \hat{\mathbf{x}}_k^p + \mathbf{C}_k^p \mathbf{H}_k^T \{ \mathbf{C}_k^y + \mathbf{H}_k^T \mathbf{C}_k^p \mathbf{H}_k \}^{-1} (\hat{y}_k - \mathbf{H}_k \hat{\mathbf{x}}_k^p) \\ \mathbf{C}_k^f &= \mathbf{C}_k^p - \mathbf{C}_k^p \mathbf{H}_k^T \{ \mathbf{C}_k^y + \mathbf{H}_k \mathbf{C}_k^p \mathbf{H}_k^T \}^{-1} \mathbf{H}_k \mathbf{C}_k^p.\end{aligned}$$

These are the time update and measurement update equations of the Kalman filter.

No Uncertainties with Known Correlation

When there are no uncertainties with known correlation, the covariance matrices \mathbf{C}_k^p and \mathbf{C}_k^y are set to zero in the above equations. The resulting predicted value and the corresponding covariance matrix are now given by

$$\begin{aligned}\hat{\mathbf{x}}_{k+1}^p &= \mathbf{A}_k \hat{\mathbf{x}}_k^f + \mathbf{B}_k \hat{u}_k, \\ \mathbf{E}_{k+1}^p &= \frac{1}{0.5 - \kappa_k} \mathbf{A}_k \mathbf{E}_k^f \mathbf{A}_k^T + \frac{1}{0.5 + \kappa_k} \mathbf{B}_k \mathbf{E}_k^u \mathbf{B}_k^T,\end{aligned}$$

with $\kappa_k \in (-0.5, 0.5)$. The resulting equations for the estimated value and its associated covariance matrix are given by

$$\begin{aligned}\hat{\mathbf{x}}_k^f &= \hat{\mathbf{x}}_k^p + \lambda_k \mathbf{E}_k^p \mathbf{H}_k^T \{ \mathbf{E}_k^y + \lambda_k \mathbf{H}_k^T \mathbf{E}_k^p \mathbf{H}_k \}^{-1} (\hat{y}_k - \mathbf{H}_k \hat{\mathbf{x}}_k^p) \\ \mathbf{E}_k^f &= (1 + \lambda_k) \mathbf{E}_k^p - (1 + \lambda_k) \lambda_k \mathbf{E}_k^p \mathbf{H}_k^T \{ \mathbf{E}_k^y + \lambda_k \mathbf{H}_k \mathbf{E}_k^p \mathbf{H}_k^T \}^{-1} \mathbf{H}_k \mathbf{E}_k^p.\end{aligned}$$

These are the time update and measurement update equations of the Covariance Intersection filter.

Hence, the new filter generalizes the Kalman filter and Covariance Intersection filter and contains them as border cases.

3. A NEW CONCEPT FOR SMBL

We consider an observer located in an environment that contains landmarks. The observer measures the positions of the landmarks relative to the observer coordinate system. The measurements are used to simultaneously estimate both the observer position and the landmark positions relative to an inertial coordinate system.

The landmark positions with respect to the inertial coordinate system are initially uncertain. In addition, measurements are corrupted by white Gaussian noise.

Landmark positions are denoted by \underline{x}_i , $i = 1, \dots, N$, the observer position by \underline{x}_R . The distance measurement to landmark i at time step k is denoted by d_k^i .

The SMBL problem could in principle be solved by a Kalman filter operating on the augmented state vector containing the observer position and all the landmark positions (global filter). Correct operation is only ensured, when the complete covariance matrix is updated and stored. Of course, for a large number of landmarks, this becomes computationally expensive.

Hence, many researchers¹² tried to reduce computational burden by just manipulating parts of the state vector (and hence of the covariance matrix) at each update step. To be specific: For the measurement of landmark i only the observer position (and uncertainty) and the position of landmark i (and uncertainty) are updated. As a result, the correlations between the individual landmarks and between the landmarks and observer are lost.

Two suboptimal fusion algorithms have been used so far in literature:

1. The resulting correlations are neglected and a standard Kalman filter is applied. This leads to overoptimistic estimation results and the filter may diverge.²
2. Observer and considered landmark are assumed to be correlated with totally unknown correlation. Methods for performing fusion in the presence of unknown correlation are available^{4,11} producing conservative estimates.

Hence, the second method is preferred. However, information about distribution or correlation of the measurement noise cannot be exploited by the previously mentioned algorithms.^{4,11}

Here, a novel dual estimation method is proposed for solving the SMBL problem in a local way: Each measurement to a landmark i at time k is employed two times: Once for updating the observer position with the previous estimate of the landmark position as reference and once for updating the landmark position with the previous estimate of the observer position as reference.

The **main contribution** of this paper is the application of the new filtering method to the SMBL problem, which allows both

- the consistent local fusion of information
- and the incorporation of additional information about the measurement noise.

For the robot position and for every landmark position, only the estimate and the corresponding covariance matrix are stored. The covariance matrix is calculated by the sum of the filter outputs E_k and C_k . Correlations between the observer and the landmarks are *not* stored. Two instances of the new filter are employed at each time step. One instance is used to update the robot position, the other one is used to update the position of the landmark measured.

When estimating the robot position based on the uncertain landmark and the measurement, there is an unknown amount of correlation between robot and landmark, because the correlation has not been stored. Hence, the observation contains both uncorrelated parts and correlated parts with unknown correlation.

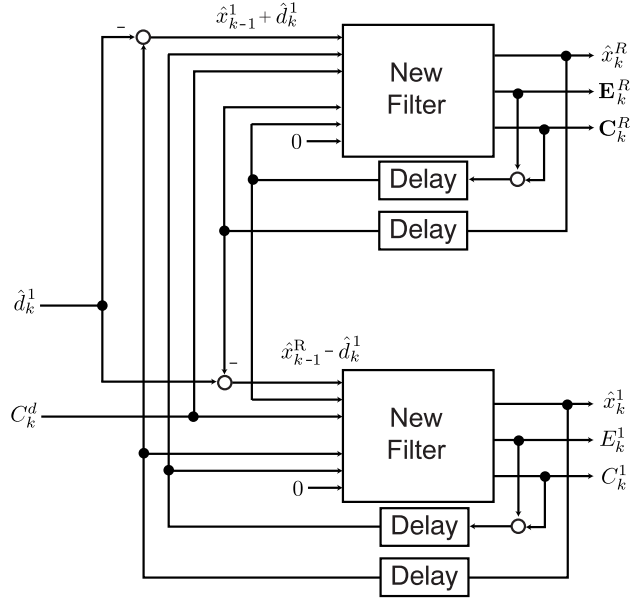

Figure 1. Block diagram of the algorithm for updating the position of wall 1 and the observer position with a measurement d_k^1 . Please note, that the observer is assumed motionless for simplicity, which allows to omit the prediction step.

4. SIMULATION EXAMPLE

We consider a simple one-dimensional static estimation example: A robot determines its position by measuring the distance between itself and two parallel walls. Since the wall positions are uncertain, both robot and wall positions are updated during the measurement process. For time steps $k = 1, \dots, 100$, only the distance to wall 1 is measured. For time steps $k = 101, \dots, 200$, the distances to both walls are measured.

The true positions of the robot, wall 1, and wall 2 are $x_R = 10000$, $x_1 = 0$, and $x_2 = 20000$, respectively. Corresponding initial estimates are $\hat{x}_0^R = 11000$, $\hat{x}_0^1 = 1000$, and $\hat{x}_0^2 = 19930$ with associated variances $E_0^R = 2000^2$, $E_0^1 = 1000^2$, and $E_0^2 = 100^2$. The cross-covariances are unknown. The distance measurements are corrupted by zero-mean white Gaussian noise with variance $C_k^d = 300^2$.

The distance measurement \hat{d}_k^1 to wall 1 at time k is used to update the robot position with the measurement equation

$$\hat{y}_k^R = x_k^R + v_k^1 \text{ where } \hat{y}_k^R = \hat{x}_{k-1}^1 + \hat{d}_k^1$$

and to update the position of wall 1 with the measurement equation

$$\hat{y}_k^1 = x_k^1 + w_k^1 \text{ where } \hat{y}_k^1 = \hat{x}_{k-1}^R - \hat{d}_k^1 .$$

v_k^1 , w_k^1 are observation uncertainties derived from the uncertainties in the measurement and in the previous estimates. The distance measurement \hat{d}_k^2 to wall 2 at time k is used to update the robot position with the measurement equation

$$\hat{y}_k^R = x_k^R + v_k^2 \text{ where } \hat{y}_k^R = \hat{x}_{k-1}^2 - \hat{d}_k^2$$

and to update the position of wall 2 with the measurement equation

$$\hat{y}_k^2 = x_k^2 + w_k^2 \text{ where } \hat{y}_k^2 = \hat{x}_{k-1}^R + \hat{d}_k^2 .$$

v_k^2, w_k^2 are again observation uncertainties derived from the uncertainties in the measurement and in the previous estimates. When the distances to both walls are measured at time k , updating the robot position with the first measurement yields an updated predicted robot position \hat{x}_{k-1}^R used for the second measurement.

Four filters are applied to this problem: A Kalman filter with full state information, which is used for reference purposes, and three filters operating locally: A standard Kalman filter,¹ a Covariance Intersection filter,¹¹ and the new filter.

The result of the Kalman filter with full state information is shown in Figure 2, where the initial covariances are assumed to be zero.

The local Kalman filter is applied by using the above measurement equations with measurement variances calculated according to

$$\begin{aligned} C_k^{v1} &= C_{k-1}^A + C_k^d ; \\ C_k^{w1} &= C_{k-1}^R + C_k^d ; \\ C_k^{v2} &= C_{k-1}^A + C_k^d ; \\ C_k^{w2} &= C_{k-1}^R + C_k^d ; \end{aligned}$$

Results of this naive application of the Kalman filter are shown in Figure 3. Uncertainty is reduced very quickly and the filter converges to the wrong value while still measuring wall 1. When wall 2 is additionally measured, the Kalman filter corrects the position of wall 2. Since wall 2 is known more precisely than wall 1, jointly correcting the robot position and the position of wall 1 would be more appropriate. Note: The confidence intervals do not contain the true values. In addition, the errors are the largest among the three filters.

For applying the Covariance Intersection filter, the above measurement equations are used with measurement variances calculated according to

$$\begin{aligned} E_k^{v1} &= E_{k-1}^A + C_k^d ; \\ E_k^{w1} &= E_{k-1}^R + C_k^d ; \\ E_k^{v2} &= E_{k-1}^A + C_k^d ; \\ E_k^{w2} &= E_{k-1}^R + C_k^d ; \end{aligned}$$

Covariance intersection leads to the results shown in Figure 4. The filter is very conservative and does not reduce the estimation variance by averaging measurements like the Kalman filter. Note: The confidence intervals contain the true values. However, the estimates are very conservative.

For applying the new filter, the uncertainties $v_k^1, w_k^1, v_k^2, w_k^2$ are rewritten as

$$\begin{aligned} v_k^1 &= e_k^{v1} + C_k^{v1} \\ w_k^1 &= e_k^{w1} + C_k^{w1} \\ v_k^2 &= e_k^{v2} + C_k^{v2} \\ w_k^2 &= e_k^{w2} + C_k^{w2} \end{aligned}$$

The corresponding variances are given by

$$\begin{aligned} E_k^{v1} &= C_{k-1}^A ; C_k^{v1} = C_k^d ; \\ E_k^{w1} &= C_{k-1}^R ; C_k^{w1} = C_k^d ; \\ E_k^{v2} &= C_{k-1}^A ; C_k^{v2} = C_k^d ; \\ E_k^{w2} &= C_{k-1}^R ; C_k^{w2} = C_k^d ; \end{aligned}$$

Results of the new filter are depicted in Figure 5. The filter reduces the estimation uncertainty based on averaging out the measurement uncertainty. However, it also considers the correlations that are built up between the robot and the walls. The estimation results are very similar to the results of the Kalman filter with full state information. **Note:** The confidence intervals contain the true values. In addition, the errors are the smallest among the three filters without full state information.

5. CONCLUSIONS

A new local solution to the SML problem has been introduced. The new approach not only allows a consistent update of observer and landmark positions despite unknown correlations. It also allows independence assumptions, for example in the measurement noise, to be exploited.

This paper was restricted to the case of linear measurement equations to clearly demonstrate the effect of different treatments of correlations without nonlinear side-effects. The problem of treating nonlinear measurement equations will be covered in a forthcoming paper.

REFERENCES

1. B. D. O. Anderson and J. B. Moore, *Optimal Filtering*, Prentice-Hall, 1979.
2. J. A. Castellanos, J. D. Tardós, and G. Schmidt, "Building a Global Map of the Environment of a Mobile Robot: The Importance of Correlations", *Proceedings of the 1997 IEEE International Conference on Robotics and Automation (ICRA'97)*, Albuquerque, New Mexico, USA, April 1997, pp. 1053–1059.
3. J. A. Castellanos, J. M. Martínez, J. Neira, J. D. Tardós: *Simultaneous Map Building for Mobile Robots: A Multisensor Fusion Approach*, IEEE International Conference on Robotics and Automation (ICRA'98), pp. 1244-1249, Leuven, Belgium, May 1998.
4. U. D. Hanebeck and G. Schmidt, "Set-theoretic Localization of Fast Mobile Robots Using an Angle Measurement Technique", *Proceedings of the 1996 IEEE International Conference on Robotics and Automation (ICRA'96)*, Minneapolis, Minnesota, USA, April 1996, pp. 1387–1394.
5. U. D. Hanebeck and J. Horn, "On Combining Set Theoretic and Bayesian Estimation", *Proceedings of the 1996 IEEE International Conference on Robotics and Automation*, Minneapolis, Minnesota, USA, April 1996, pp. 3081–3086.
6. U. D. Hanebeck and J. Horn, "A New State Estimator for a Mixed Stochastic and Set Theoretic Uncertainty Model", *Proceedings of SPIE Vol. 3720*, AeroSense Symposium, Orlando, Florida, USA, April 1999, pp. 336–344.
7. U. D. Hanebeck and J. Horn, "A New Estimator for Mixed Stochastic and Set Theoretic Uncertainty Models Applied to Mobile Robot Localization", *Proceedings of the 1999 IEEE International Conference on Robotics and Automation (ICRA'99)*, Detroit, Michigan, USA, May 1999, pp. 1335–1340.
8. U. D. Hanebeck, J. Horn, and G. Schmidt, "On Combining Statistical and Set-Theoretic Estimation", *Automatica*, Vol. 35, No. 6, 1999, pp. 1101–1109.
9. U. D. Hanebeck and J. Horn, "New Estimators for Mixed Stochastic and Set Theoretic Uncertainty Models: The Vector Case", *Proceedings of the Fifth European Control Conference (ECC'99)*, Karlsruhe, Germany, August/September 1999.
10. U. D. Hanebeck and J. Horn, "New Results for State Estimation in the Presence of Mixed Stochastic and Set Theoretic Uncertainties", *Proceedings of the 1999 IEEE Systems, Man, and Cybernetics Conference (SMC'99)*, Tokyo, Japan, October 1999.
11. S. J. Julier and J. K. Uhlmann, "A non-divergent estimation algorithm in the presence of unknown correlations", *Proceedings of the 1997 American Control Conference*, Albuquerque, New Mexico, USA, June 1997, pp. 2369-2373.
12. J. L. Leonard and H. F. Durrant-Whyte, *Directed sonar sensing for mobile robot navigation*, Kluwer, 1992.

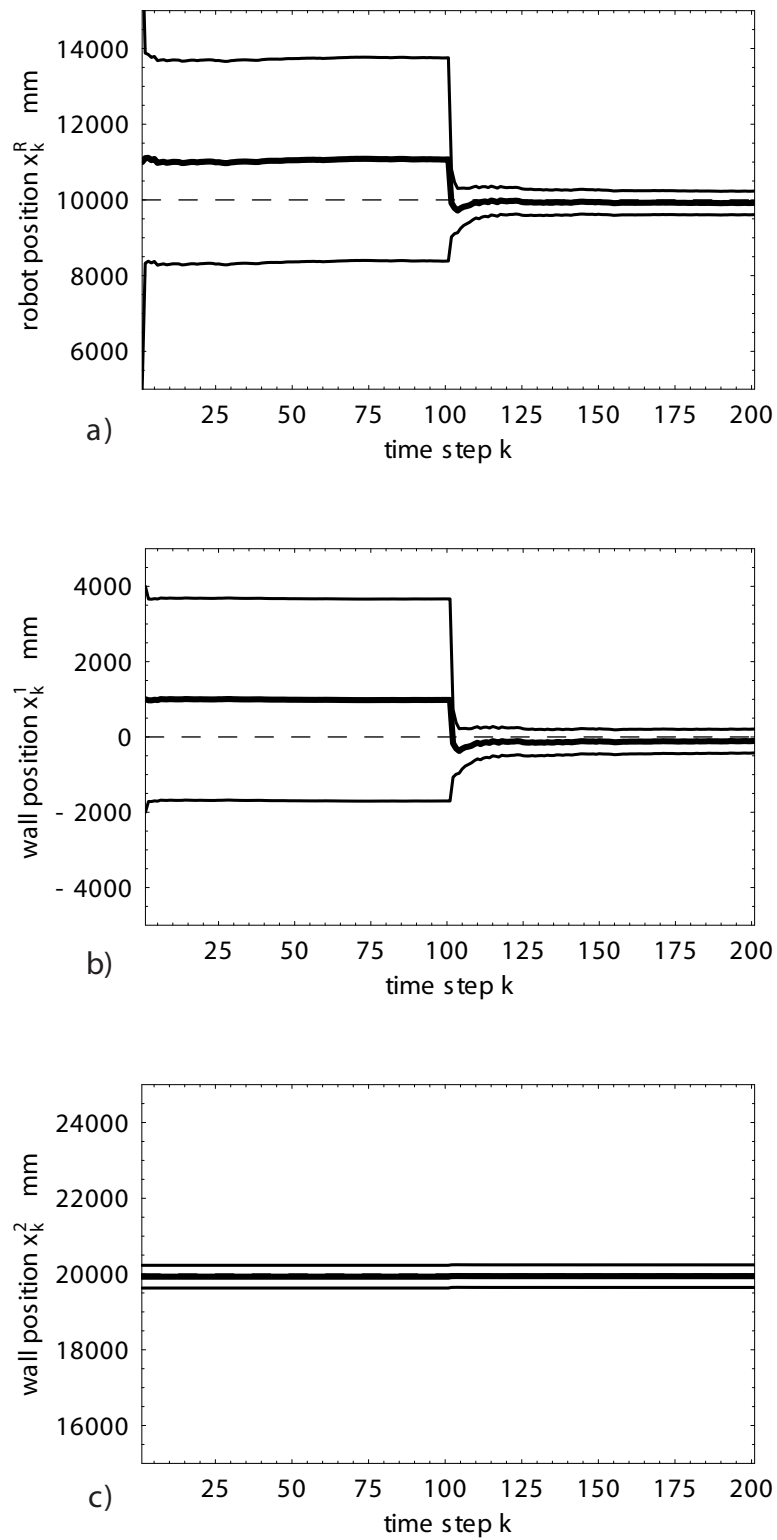

Figure 2. Results of applying the full state Kalman filter. a) Estimate of robot position. b) Estimate of position of wall 1. c) Estimate of position of wall 2. The figure shows the evolution of the estimated value (thick line) and the evolution of the 3 σ bounds.

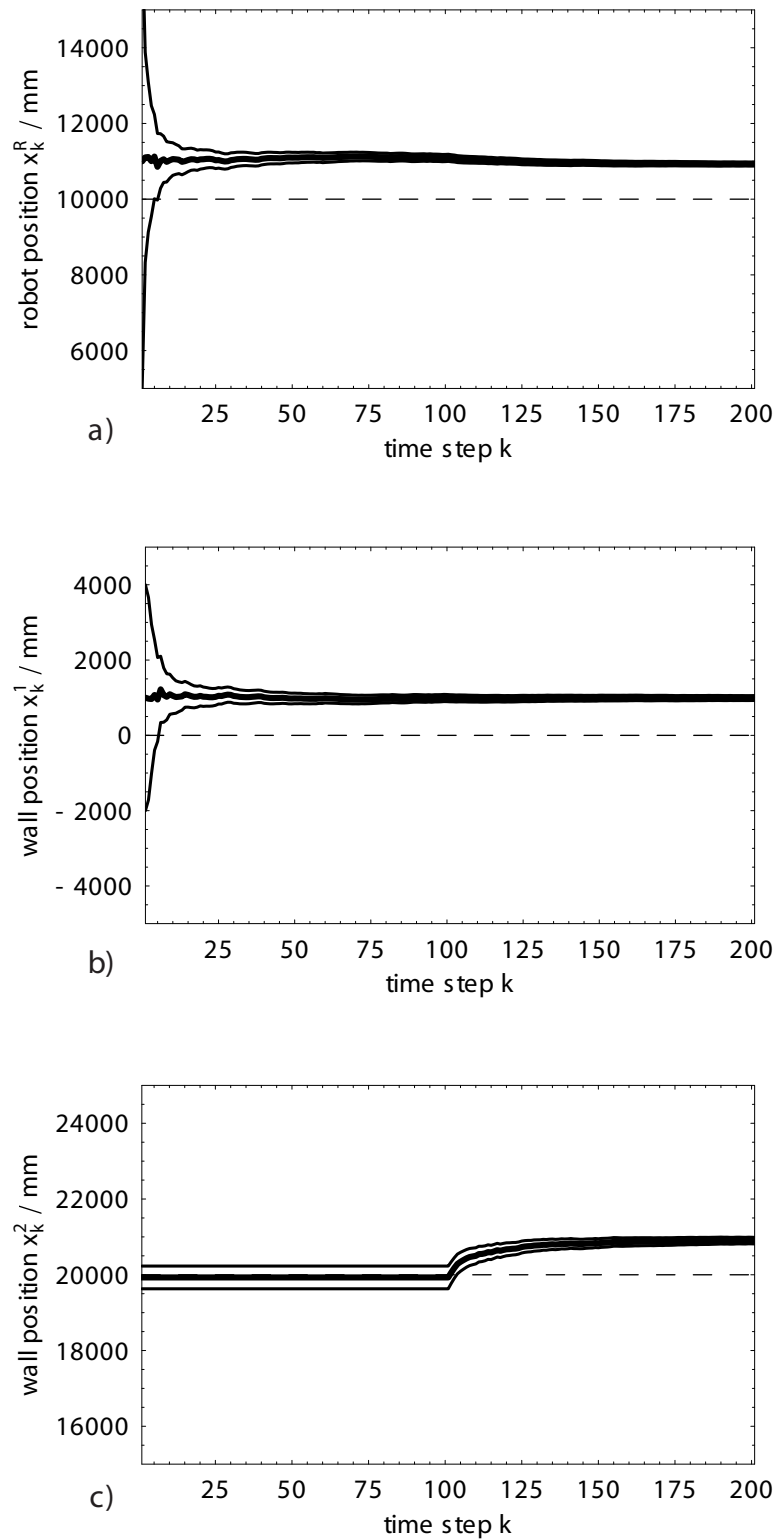

Figure 3. Results of applying the Kalman filter locally. a) Estimate of robot position. b) Estimate of position of wall 1. c) Estimate of position of wall 2. The figure shows the evolution of the estimated value (thick line) and the evolution of the 3 σ bounds.

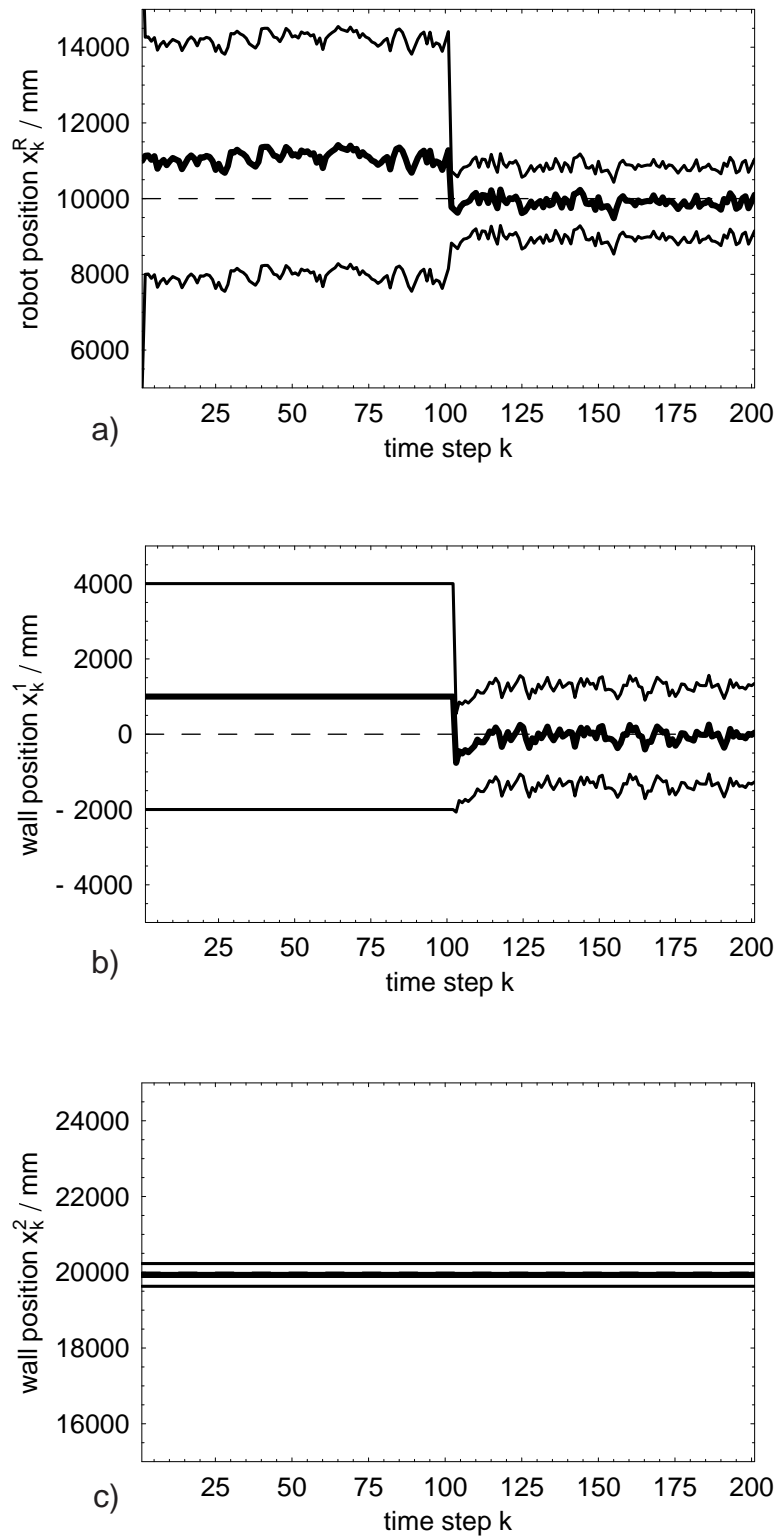

Figure 4. Results of applying the Covariance Intersection filter. a) Estimate of robot position. b) Estimate of position of wall 1. c) Estimate of position of wall 2. The figure shows the evolution of the estimated value (thick line) and the evolution of the 3σ -bounds.

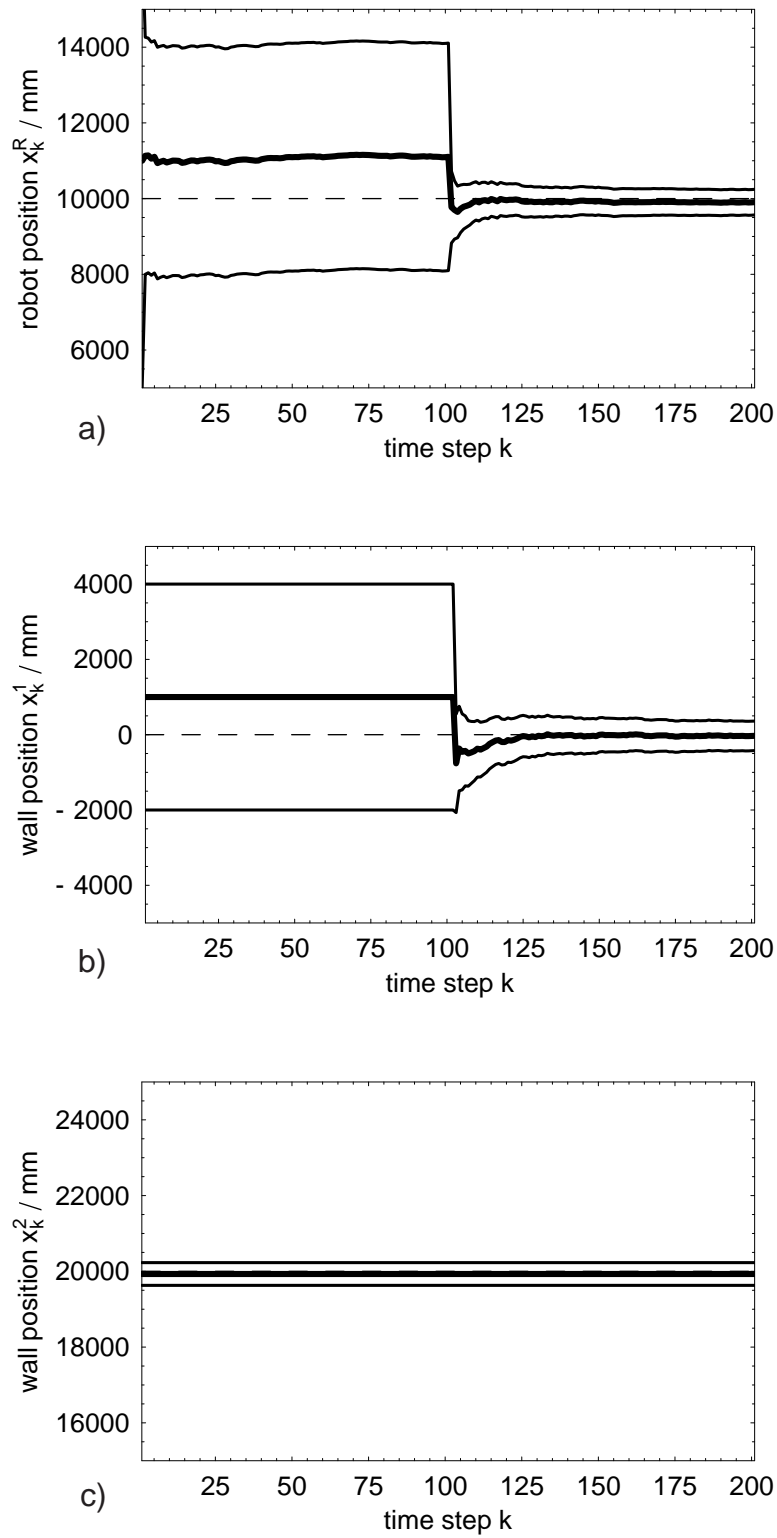

Figure 5. Results of applying the proposed new filter. a) Estimate of robot position. b) Estimate of position of wall 1. c) Estimate of position of wall 2. The figure shows the evolution of the estimated value (thick line) and the evolution of the 3σ -bounds.